

Grote sweep & collect zuigwagens met wings S10w - S20w

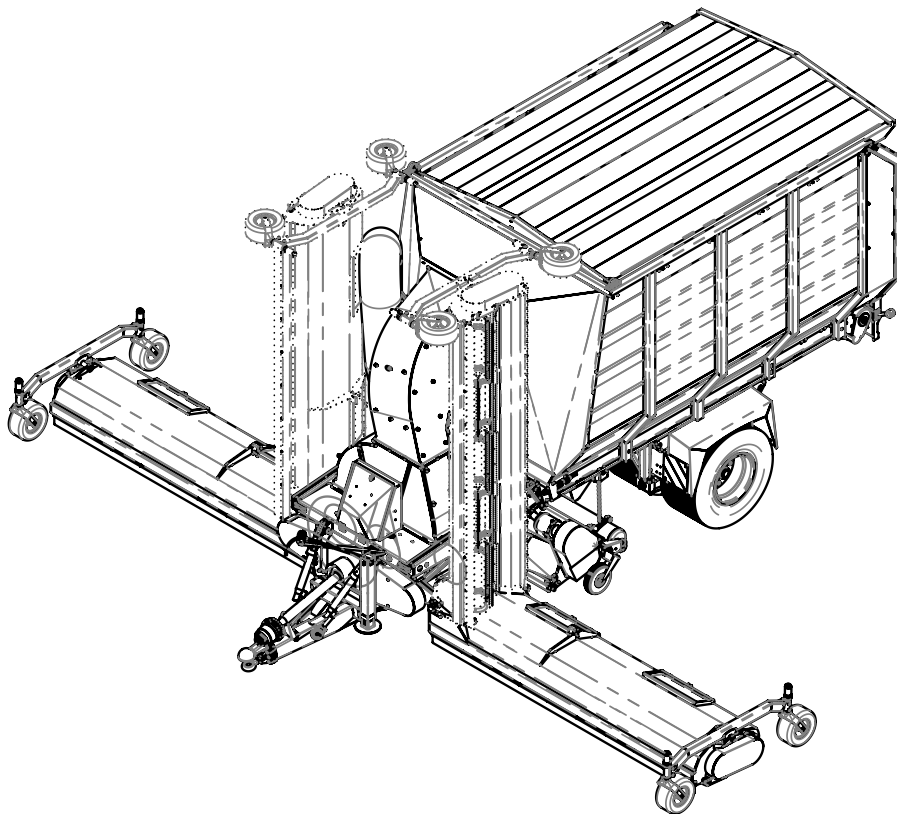

Technische specificaties

Diameter turbine/waaierblad:	Ø 960 mm
Aantal bladen waaierblad:	6
Aftakas vermogen:	90 - 110 pk (66 - 81 KW)
Aftakas-aandrijving:	540/750/1000 RPM
Aandrijving:	Aftakas
Benodigde oliecapaciteit (hydrauliek) voertuig:	180 bar - 40 l/min.
Benodigde aansluitingen voor hydrauliek:	2x dubbelwerkende aansluitingen
Gewicht:	Hangt af van de configuratie
Afmeting (LxBxH):	Hangt af van de configuratie
Luchtcapaciteit:	390 m ³ /min.
Geluidsvermogen:	85 dB(A)
Inhoud laadbak:	10 - 12 - 14 - 16 m ³
Werkbreedte:	6 - 8 m
Banden:	505/50R17 of 435

In het kader van ons beleid van voortdurende verbetering behouden wij ons het recht voor om specificaties en ontwerpen zonder voorafgaande kennisgeving te wijzigen. De illustraties zijn niet per se de standaardversie van de machine.

TRILO[®]

Grote sweep & collect zuigwagens met wings S10w - S20w

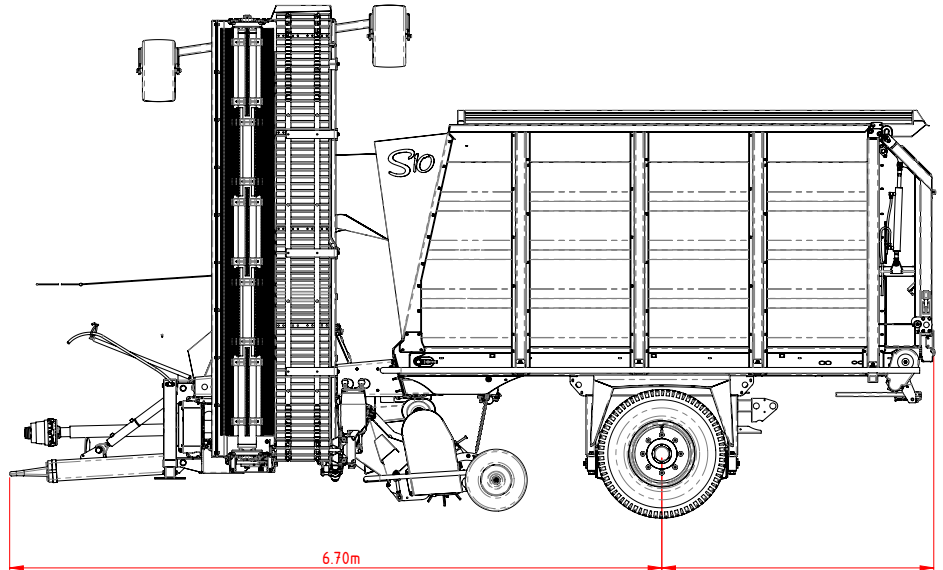
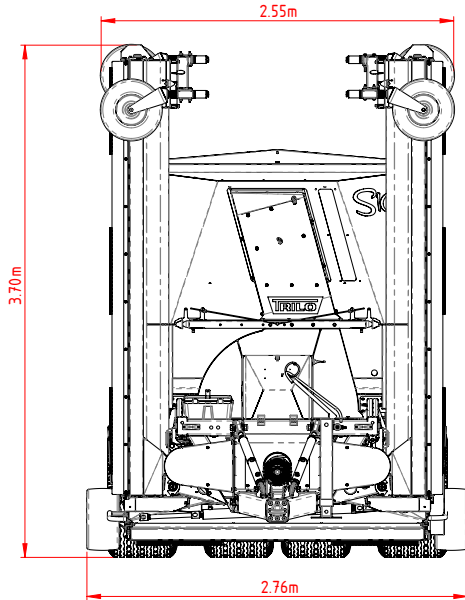

10 m³

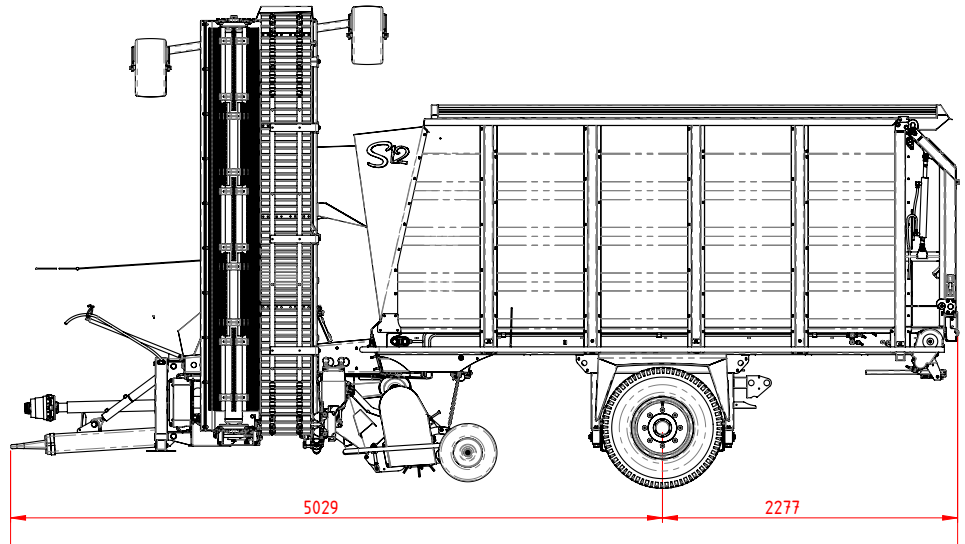
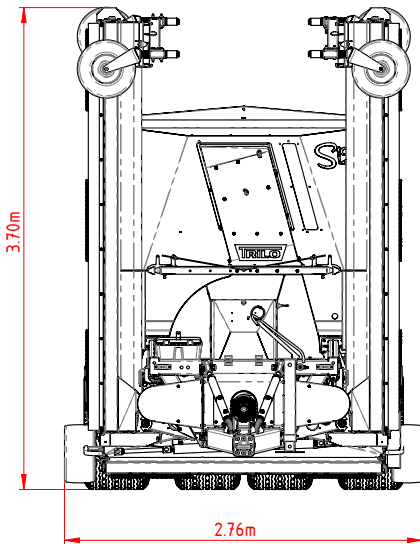

Measures are in mm

12 m³

In het kader van ons beleid van voortdurende verbetering behouden wij ons het recht voor om specificaties en ontwerpen zonder voorafgaande kennisgeving te wijzigen. De illustraties zijn niet per se de standaardversie van de machine.



Grote sweep & collect zuigwagens met wings S10w - S20w

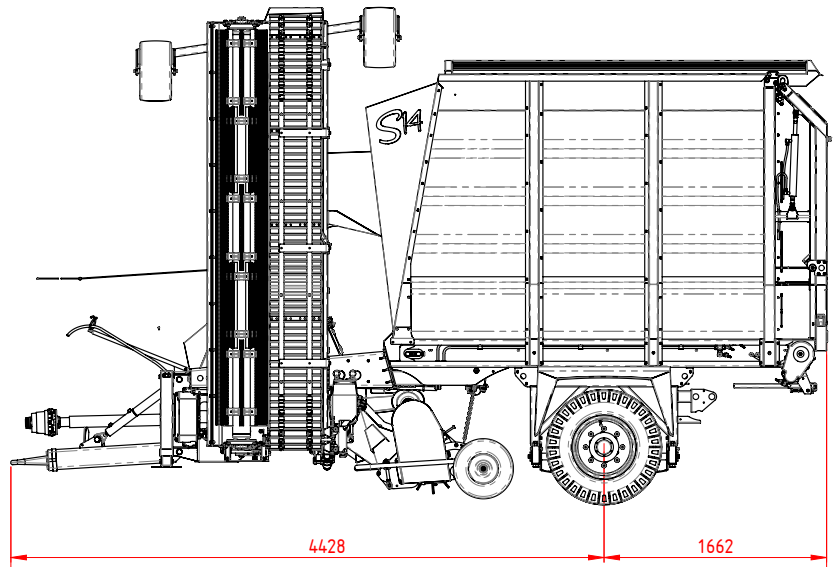
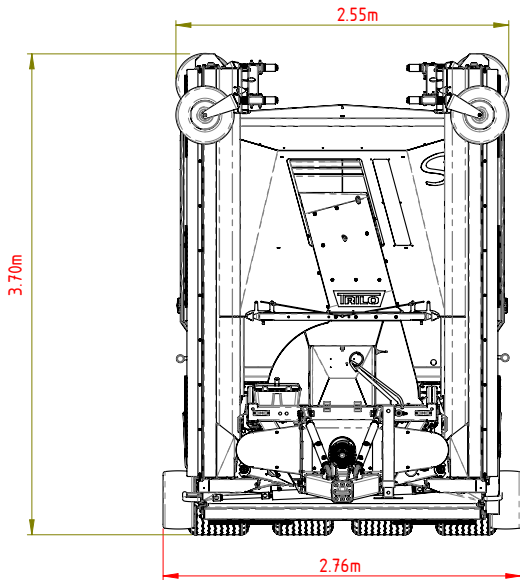

Measures are in mm

14 m³

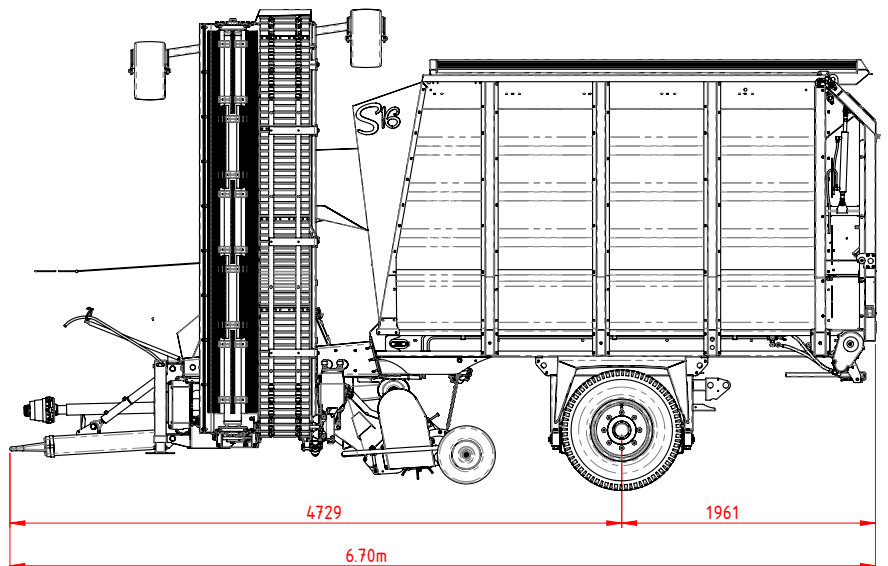
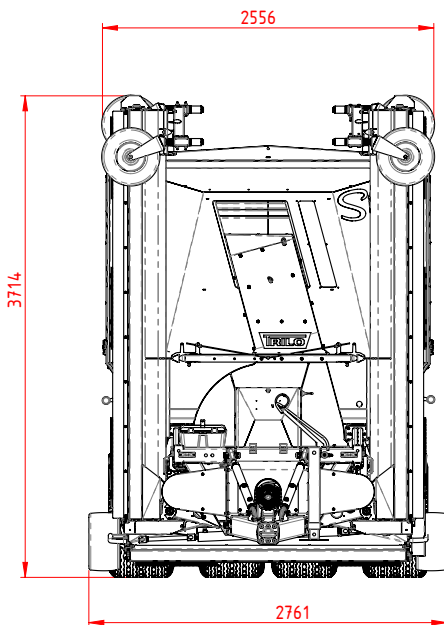

Measures are in mm

16 m³



Grote sweep & collect zuigwagens met wings S10w - S20w

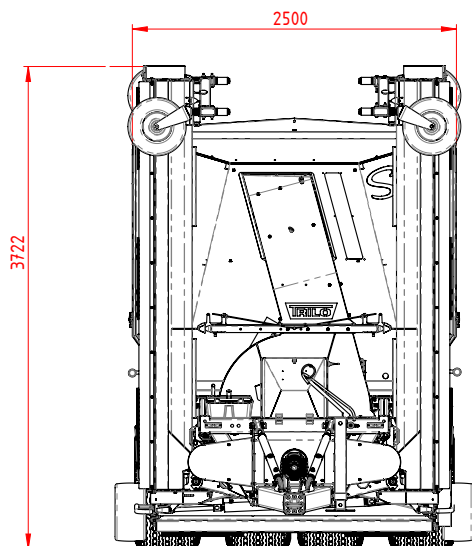

20 m³

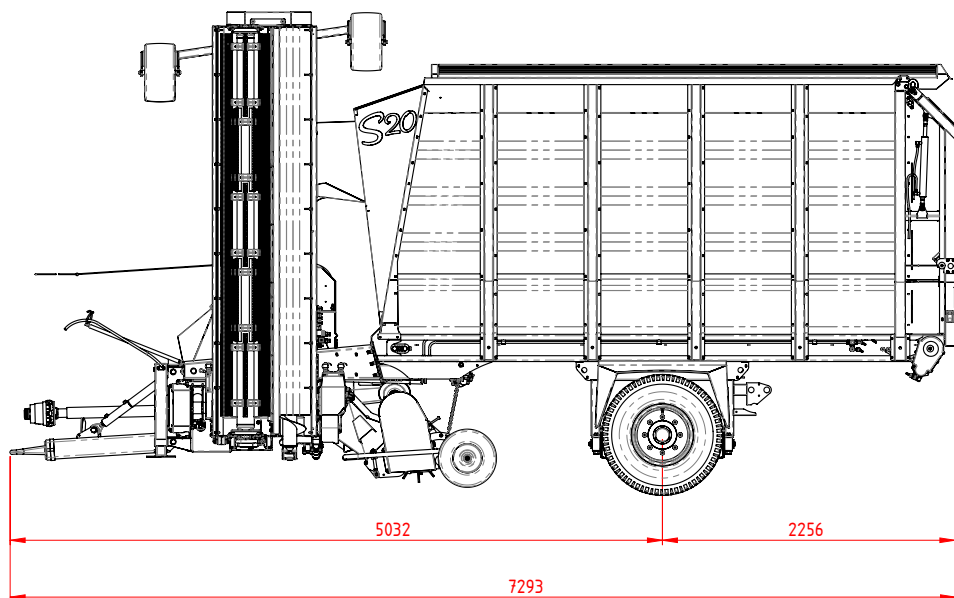

Measures are in mm

Onderstellen overzicht S10w - S20w

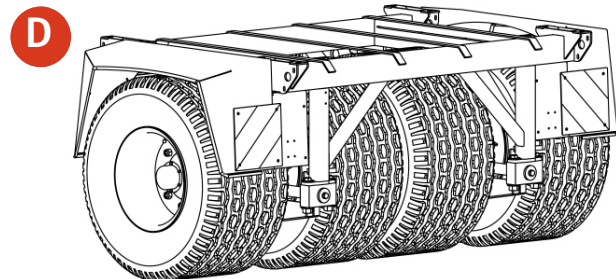
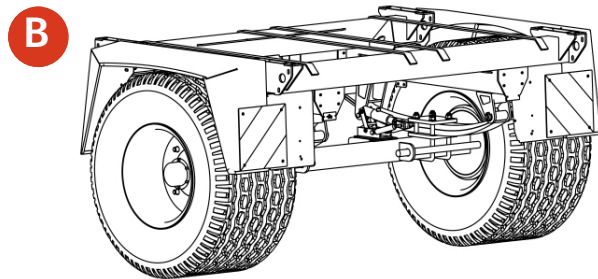
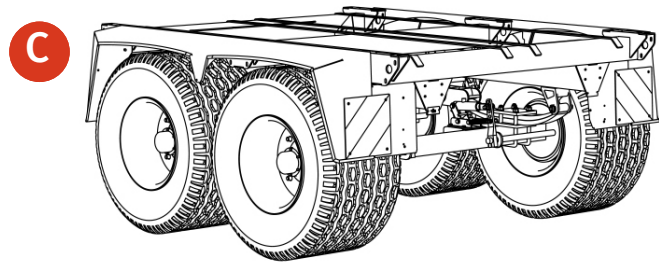
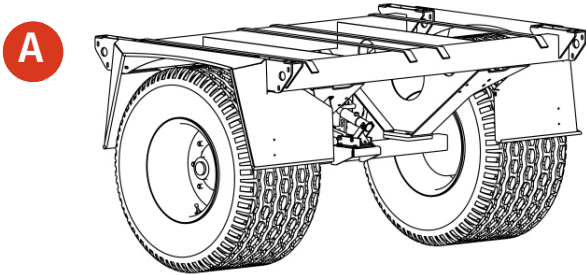

Bogie Type	A	B	C	D
Overall Width	Single 2.00 m	Single 2.30 m	Tandem 2.30 m	Pendling 2.50 m
Parabolic Spring	-	●	●	●
Dual Air Brakes	●	●	●	●
Dual Hydraulic Brakes	●	●	●	●
Single Hydraulic Brakes	●	●	●	●
Overrun Brakes	●	●	-	-
Lawn Tyres 500/50R17	●	●	●	●
Ridemax 500/50R17 Tyres	●	●	●	●
Marathon 435/50R19 Tyres	●	●	●	-
Available on model:				
S8	●	●	-	-
S10	●	●	●	●
S12	-	●	●	●
S14	-	●	-	●
S16	-	-	●	●
S20	-	-	●	●