

## Barredoras aspiradoras grandes con alas S10w - S16w

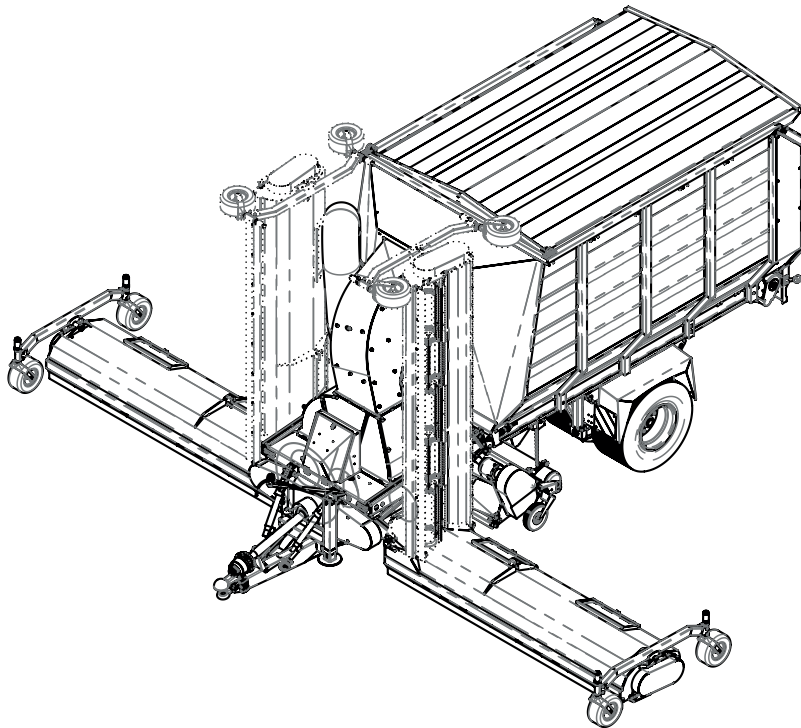

### Especificaciones técnicas

Diámetro de la turbina / impulsor:	Ø 960mm
Nº aspas del impulsor:	6
Potencia requerida:	80 - 100 pk (59 - 74 KW)
Toma de fuerza:	540/750/1000 RPM
Accionamiento:	TDF
Capacidad hidráulica requerida-vehículo:	180 bar - 40 l/min.
Conexión hidráulica requerida:	2x doble acción
Peso:	Depende de configuración
Dimensiones (LxANxAL):	Depende de configuración
Flujo de aire:	390 m <sup>3</sup> /min.
Emisión sonora:	85 dB(A)
Volumen Tolva:	8 - 10 - 12 - 14 - 16 m <sup>3</sup>
Ancho trabajo-Campana de succión:	6 - 8 m
Neumáticos:	505/50R17 or 435

**TRILO**

## Barredoras aspiradoras grandes con alas S10w - S16w

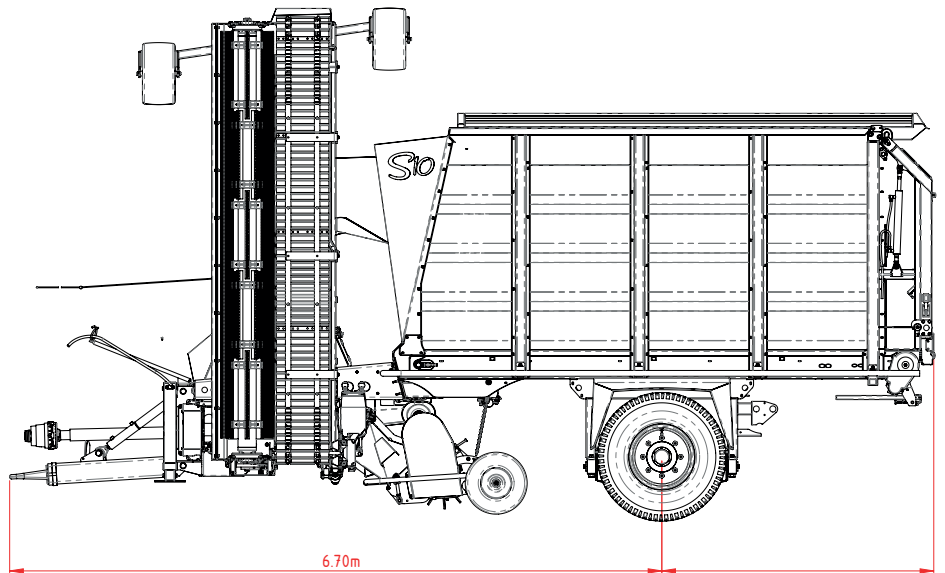
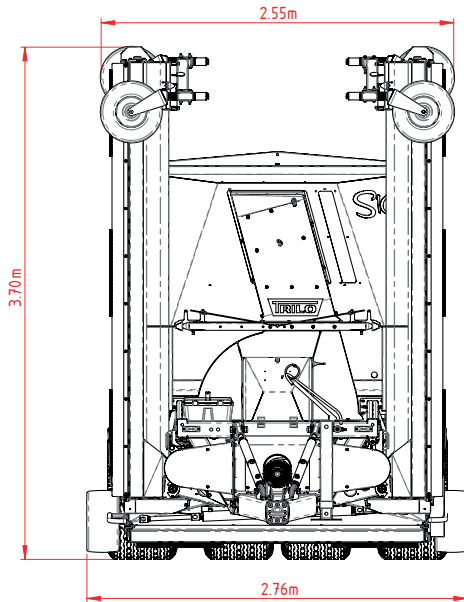

10 m<sup>3</sup>

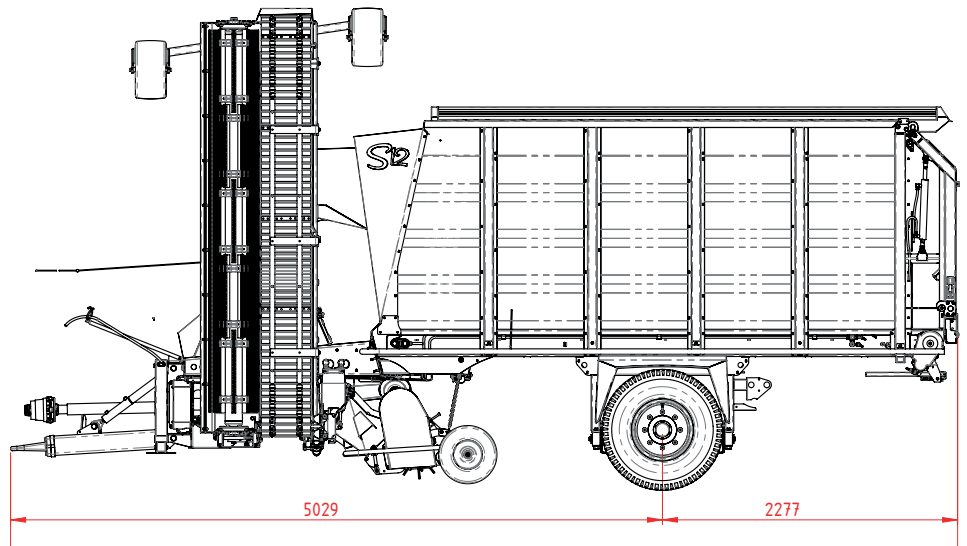
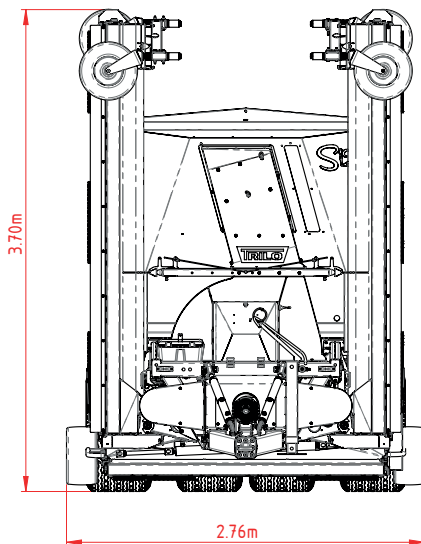

Measures are in mm

12 m<sup>3</sup>

Bajo nuestra política de mejora continua, nos reservamos el derecho de cambiar las especificaciones y el diseño sin previo aviso. Las ilustraciones no necesariamente muestran la versión estándar de la máquina.



## Barredoras aspiradoras grandes con alas S10w - S16w

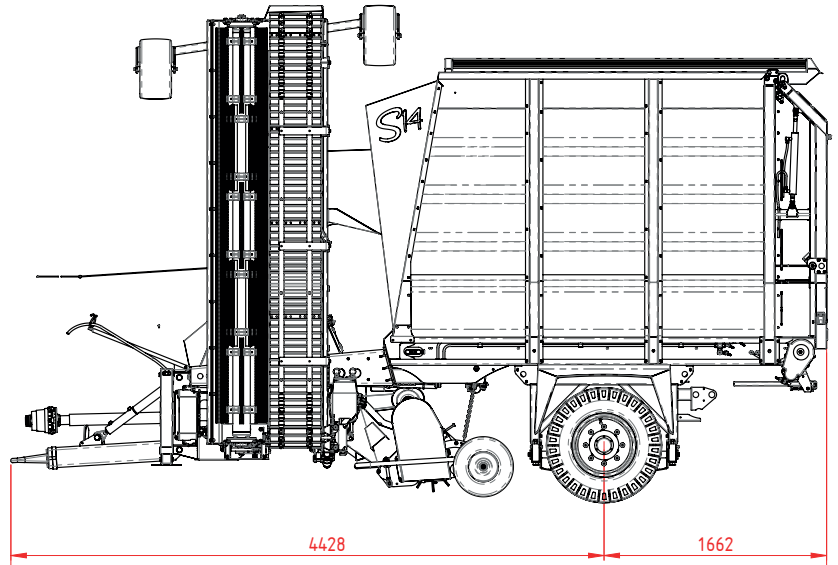
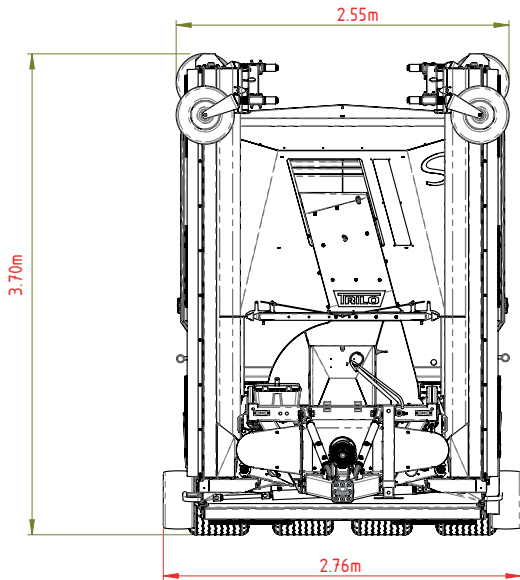

14 m<sup>3</sup>

Measures are in mm

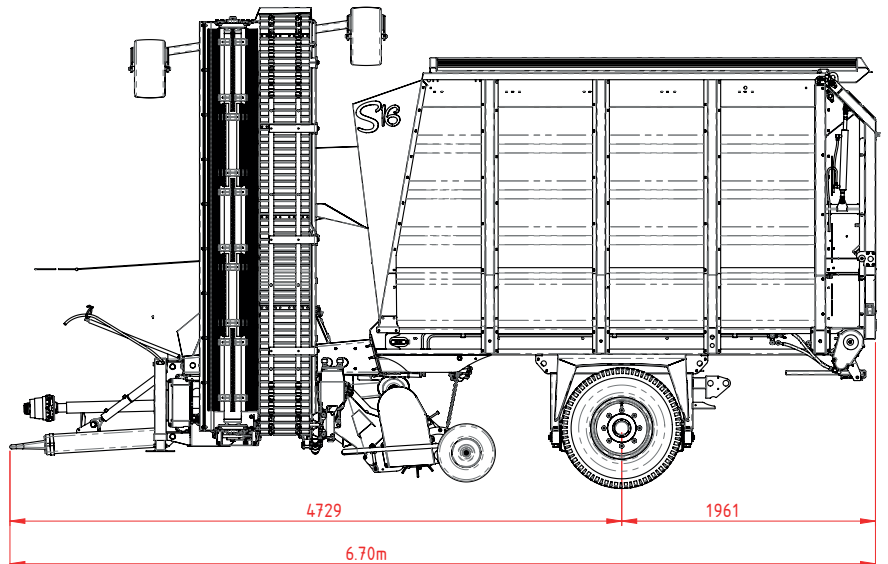
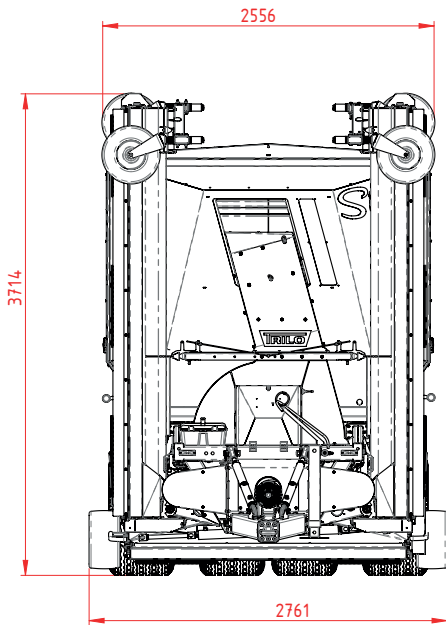

16 m<sup>3</sup>

Measures are in mm

Bajo nuestra política de mejora continua, nos reservamos el derecho de cambiar las especificaciones y el diseño sin previo aviso. Las ilustraciones no necesariamente muestran la versión estándar de la máquina.

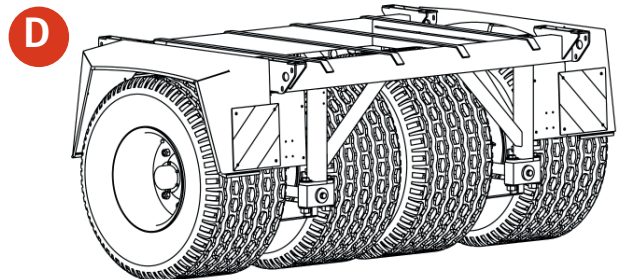
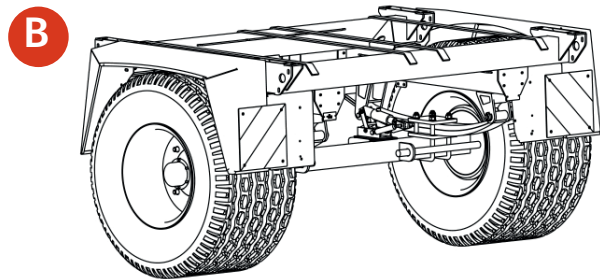
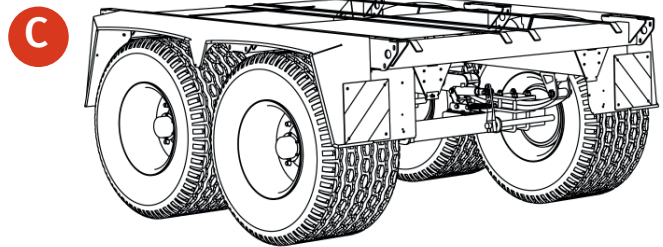
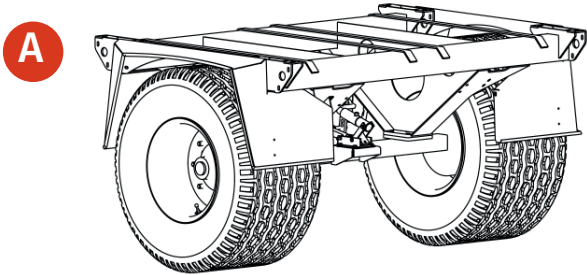

Bogie Type	A	B	C	D
Overall Width	Single 2.00 m	Single 2.30 m	Tandem 2.30 m	Pendling 2.50 m
Parabolic Spring	-	●	●	●
Dual Air Brakes	●	●	●	●
Dual Hydraulic Brakes	●	●	●	●
Single Hydraulic Brakes	●	●	●	●
Overrun Brakes	●	●	-	-
Lawn Tyres 500/50R17	●	●	●	●
Ridemax 500/50R17 Tyres	●	●	●	●
Marathon 435/50R19 Tyres	●	●	●	-
<b>Available on model:</b>				
S8	●	●	-	-
S10	●	●	●	●
S12	-	●	●	●
S14	-	●	-	●
S16	-	-	●	●
S20	-	-	●	●