

# VCU200 Verticutting units

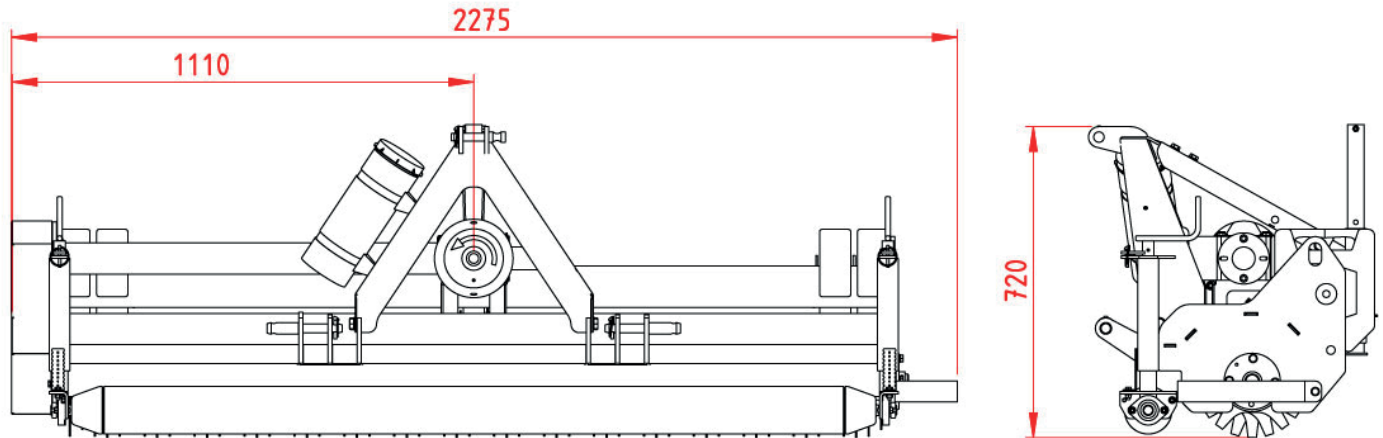

Measures are in mm

## Technische specificaties

PTO output:	> 30 hp (22 kW)
PTO:	540 RPM
Drive:	Power take-off
Three point hitch:	Cat. I
Weight:	265 kg (584 lb)
Measurements (LxWxH):	2,20 x 0,80 x 0,90 m (7.21 x 2.62 x 2.95 ft)
Working width:	2,00 m (6.56 ft)
Number of knives:	73 / 66 / 40
Diameter knives:	Ø 270 mm (10.6")
Knife thickness:	3 mm (0.11") Tungsten Tips or 3 mm (0.11") Manganese steel
Knife distance:	30 mm (1.18")
Front roller diameter:	Ø 120 mm (4.72")
Weight set:	4 x 22 kg (48.5 lb)
Working depth:	Max. 40 mm (1.57")

Under our policy of continuous improvement, we reserve the right to change specifications and design without prior notice. The illustrations do not necessarily show the standard version of the machine.



## VCU200 Verticutting units

