



Grandes caminhões a vácuo multifuncionais (M8 - M20)

Especificações técnicas

Diâmetro do ventilador:	Ø 960mm
Número de lâminas do ventilador:	6
Potência de TDF com mangueira de sucção:	65 - 100 cv (49 - 75 kW)
Potência de TDF deslizar e coletar:	75 - 110 cv (51 - 81 kW)
Potência de TDF corte e coleta:	90 - 130 cv (66 - 130 kW)
TDF:	540/750/1000 RPM
Acionamento:	Tomada de força
Requisitos do sistema hidráulico:	180 bar - 40 l/min.
Ligações hidráulicas necessárias:	2x mínimo de dupla ação
Capacidade de ar:	390 m ³ /min.
Nível de ruído:	85 dB(A)
Capacidade de carregamento	8 - 10 - 12 - 14 - 16 - 20 m ³
mangueira de desvio:	Ø 250 - 5 + 1 m
Mangueira de sucção:	Ø 350mm - 4 m
Comprimento funcional:	180 - 210 - 240 - 300cm
Pneus:	505/50R17 or 435

8 m³

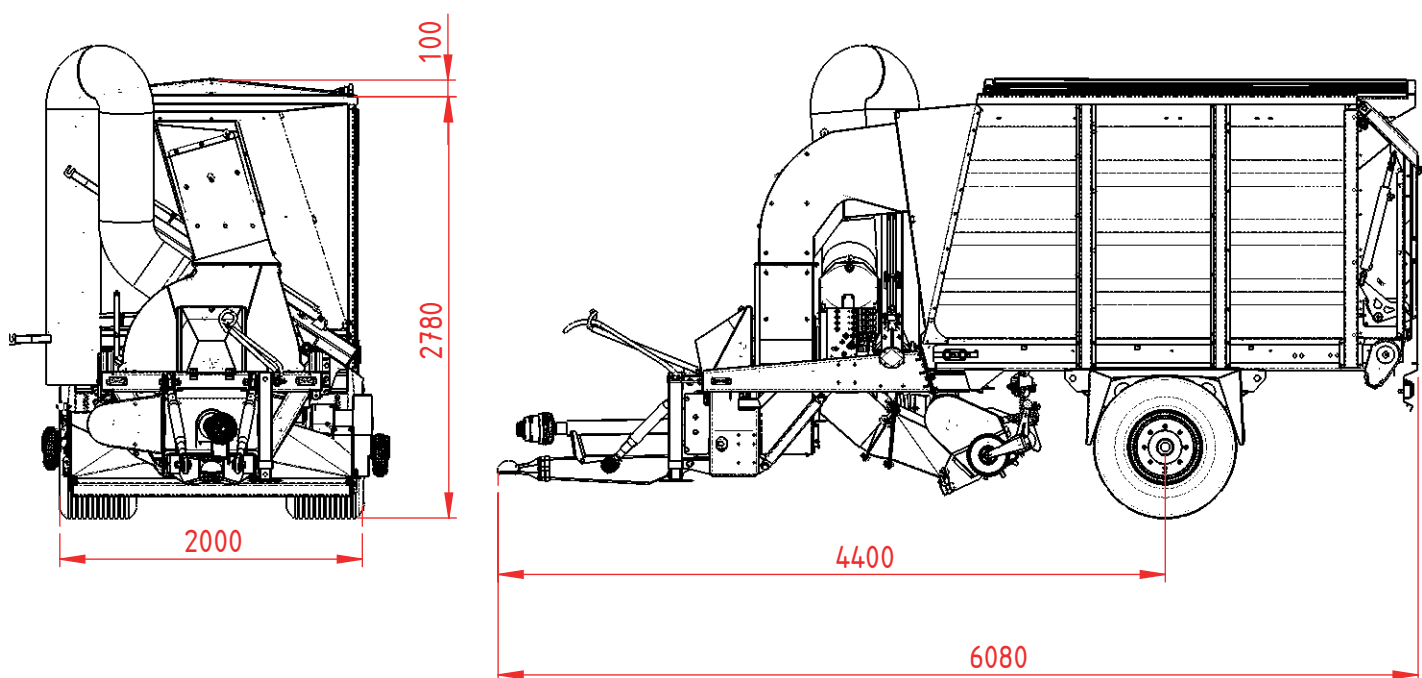

Sob nossa política de melhoria contínua, nos reservamos o direito de alterar as especificações e o design sem aviso prévio. As ilustrações não necessariamente mostram a versão padrão da máquina.

10 m³

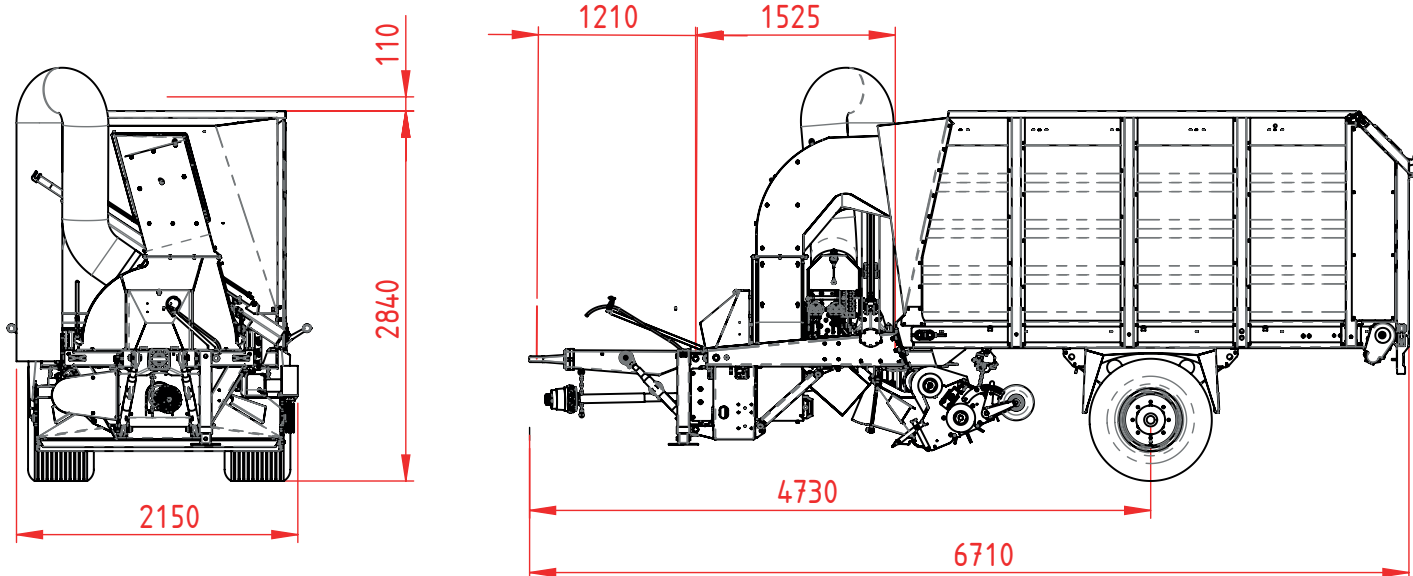

12 m³

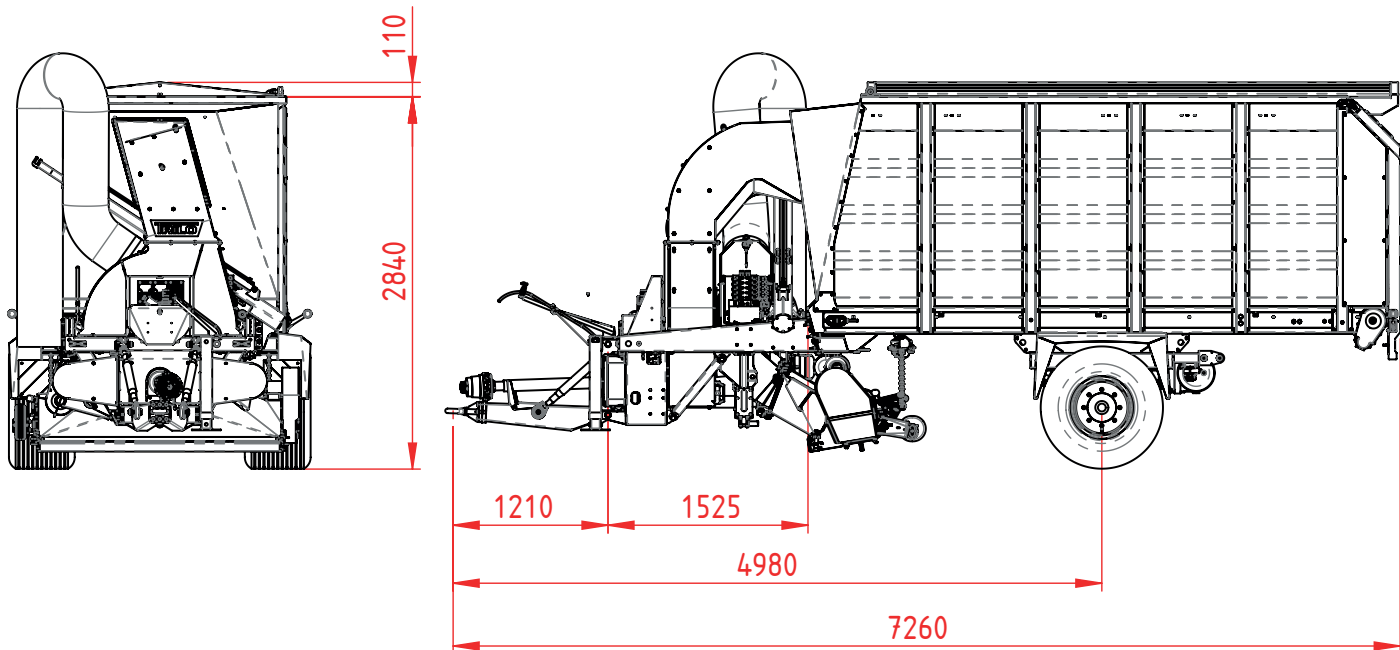

Sob nossa política de melhoria contínua, nos reservamos o direito de alterar as especificações e o design sem aviso prévio. As ilustrações não necessariamente mostram a versão padrão da máquina.



14 m³

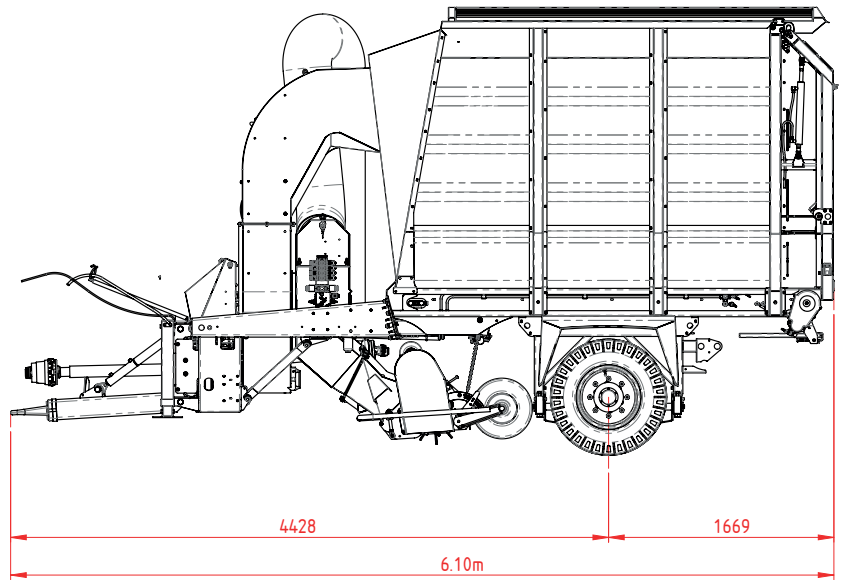
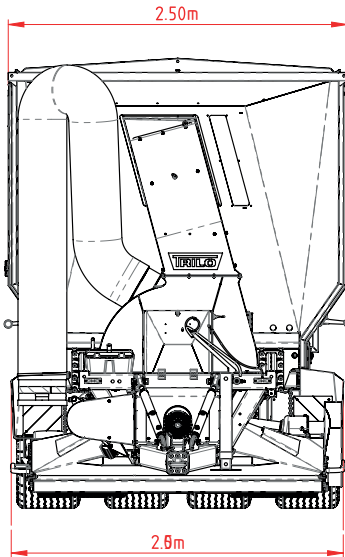

16 m³

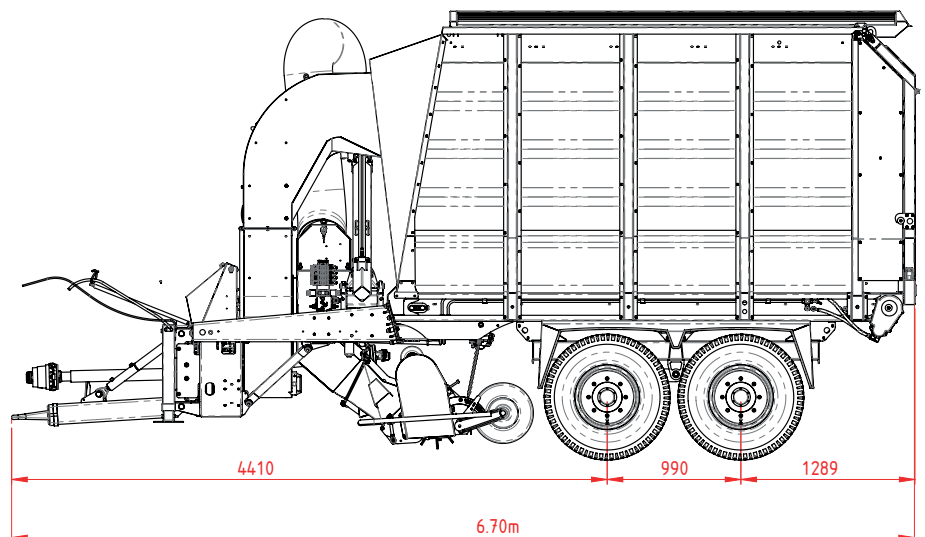
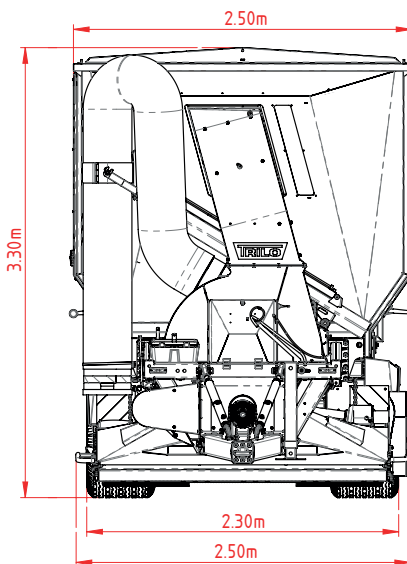

Sob nossa política de melhoria contínua, nos reservamos o direito de alterar as especificações e o design sem aviso prévio. As ilustrações não necessariamente mostram a versão padrão da máquina.

TRILO[®]

20 m³

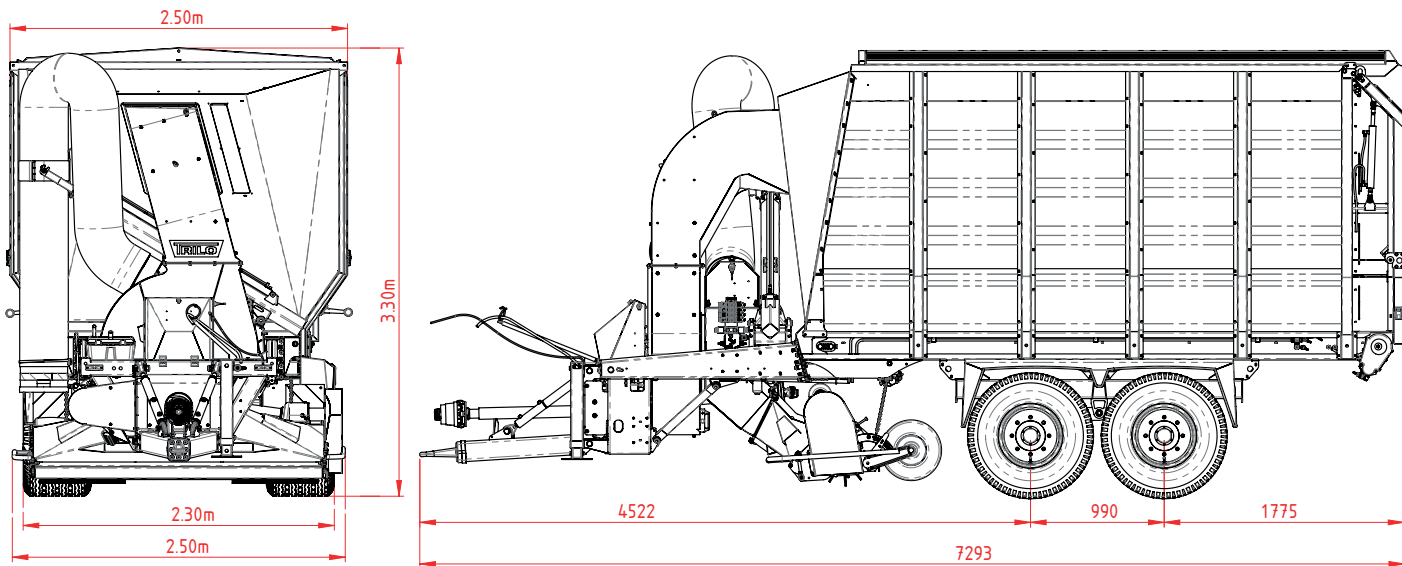

Sob nossa política de melhoria contínua, nos reservamos o direito de alterar as especificações e o design sem aviso prévio. As ilustrações não necessariamente mostram a versão padrão da máquina.



Hose arm

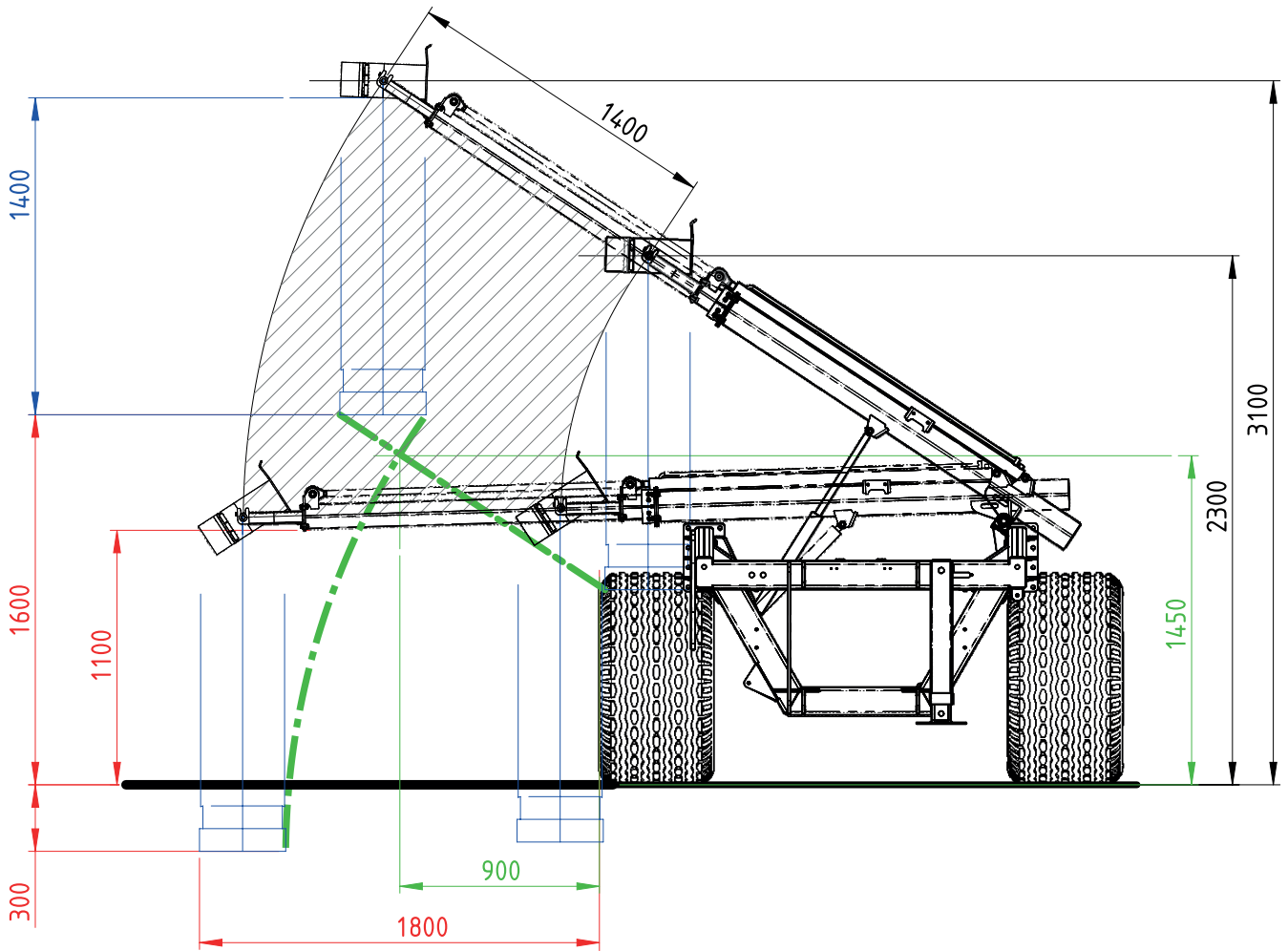

Under our policy of continuous improvement, we reserve the right to change specifications and design without prior notice. The illustrations do not necessarily show the standard version of the machine.

Suction hood width

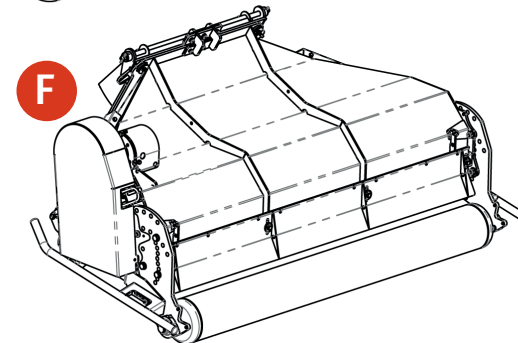
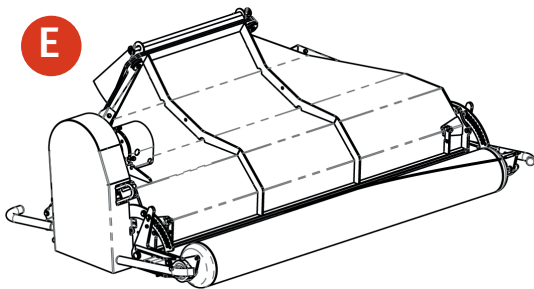
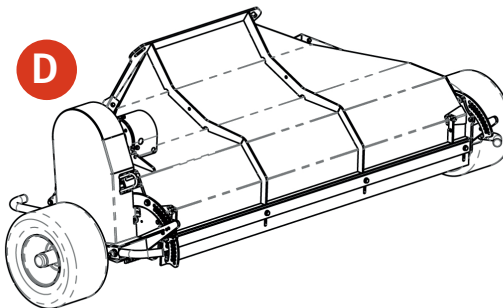
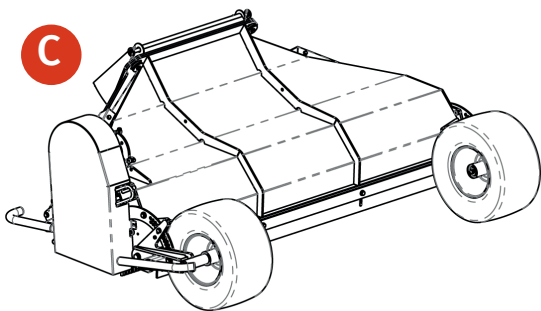
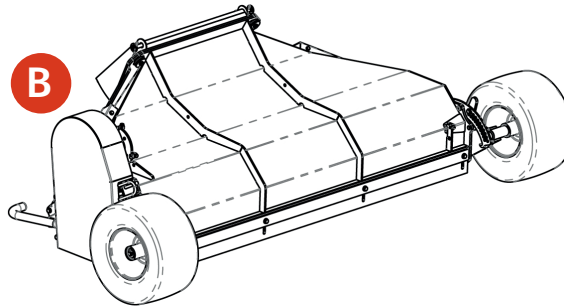
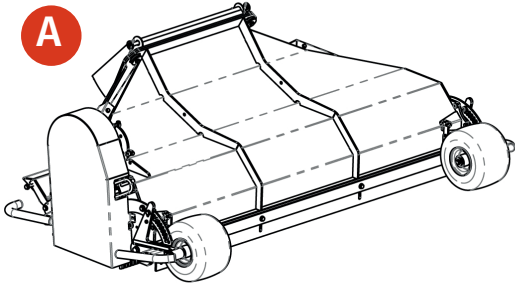

Type	Roller/Tyre	Roller/Tyre Type	Height range	Working width - Overall width				Field of application
				1.80 m	2.10 m	2.40 m	3.00 m	
A	11 x 7.00 (Default)	Air or Foam Filled Tyre	-5..13 cm	2.12 m	2.42 m	2.72 m	3.32 m	General, Road use, Offroad, Compact
B	18 x 9.50 (Slick)	Air or Foam Filled Tyre	-5..15 cm	2.46 m	2.76 m	3.06 m	3.66 m	Turf Production Wide Area Collector
C	18 x 9.50 (Slick)	Air or Foam Filled Tyre	-5..15 cm	2.12 m	2.42 m	2.72 m	3.32 m	Turf Production Wide Area Collector
D	16 x 9.50	Air or Foam Filled Tyre	-5..10 cm	2.70 m	3.00 m	3.30 m	3.90 m	Golf course
E	Roller (Default)	Steel	-5..15 cm	2.12 m	2.42 m	2.72 m	x	Mowing
F	Roller HD	Steel	-5..24	2.14 m	2.44m	2.74m	x	Mowing (high cut)

Undercarriage overview

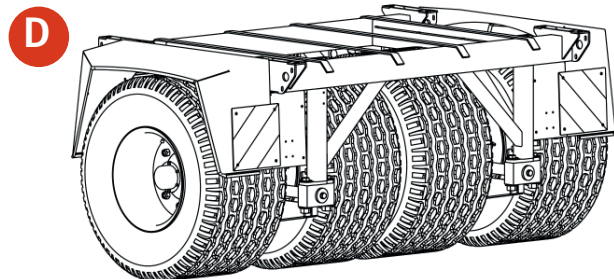
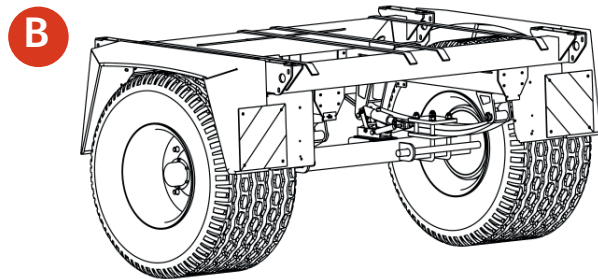
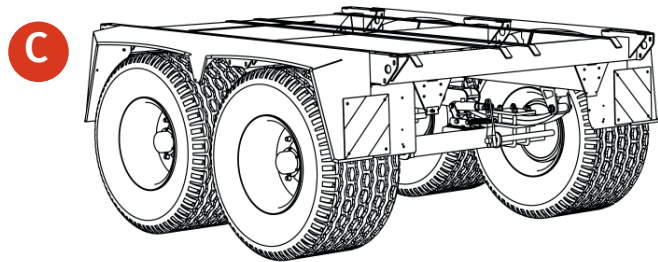
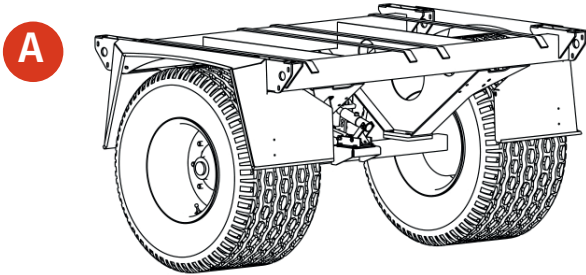

Bogie Type	A	B	C	D
Overall Width	Single 2.00 m	Single 2.30 m	Tandem 2.30 m	Pendling 2.50 m
Parabolic Spring	-	●	●	●
Dual Air Brakes	●	●	●	●
Dual Hydraulic Brakes	●	●	●	●
Single Hydraulic Brakes	●	●	●	●
Overrun Brakes	●	●	-	-
Lawn Tyres 500/50R17	●	●	●	●
Ridemax 500/50R17 Tyres	●	●	●	●
Marathon 435/50R19 Tyres	●	●	●	-
Available on model:				
S8	●	●	-	-
S10	●	●	●	●
S12	-	●	●	●
S14	-	●	-	●
S16	-	-	●	●
S20	-	-	●	●