

PROPRIETARY AND CONFIDENTIAL
Any reproduction in part or as a whole without
the written permission on VANMAC BV is prohibited.

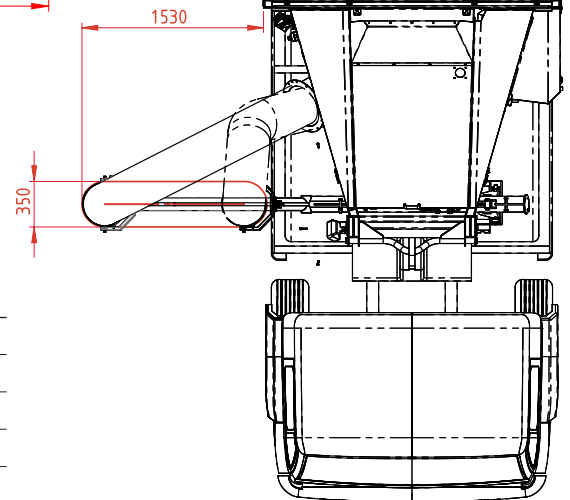
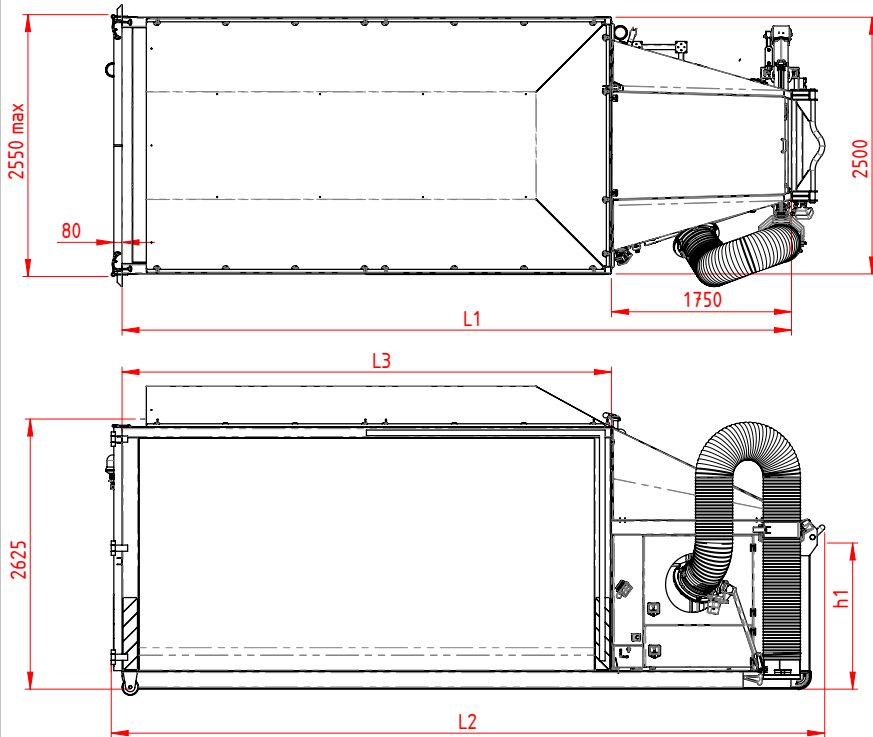

Nr	Inhalt [m ³]	L1*	L2	L3
1	17	5000	5443	3256
2	20	5500	5943	3756
3	22	6000	6443	4256
4	25	6500	6943	4756
5	28	7000	7443	5256

* DIN Abmessungen (DIN 30722)

Auf mobile Weise große Mengen an Laub und Restmüll sammeln

Antrieb: 4-Zylinder Hatz-Dieselmotor (Stufe 5)

Erhältliche Ladevolumen: 17, 20, 22, 25, 28 m³

Saugschlauch: Ø 350 mm, Länge 4 m

Bedienung: Funkfernsteuerung

Befestigung am Fahrzeug: Hakenlift- und Kabellift-System

Vanmac BV
Astronaut 40
3824 MJ AMERSFOORT
the Netherlands

Tolerances unless stated:
ISO 2768-mK
Precision Casting:
ISO 8062-3 DCTG-8
Sheet-Metal Bending:
ISO 2768-cL

DO NOT SCALE DRAWING

TS Saugcontainers

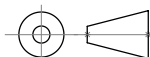

Remove welding spatter
Sheet metal unscratched
Debur / Break sharp edges

20 - 20 - 2019